



SISTEMA DE GESTIÓN DE COMBUSTIBLE



DISPENSADORES



KITS



BOMBAS



MEDIDORES



PISTOLAS

PANTHER AC

CARACTERÍSTICAS

- DISEÑO COMPACTO Y ROBUSTO
- LIGERA PARA TRABAJAR
- FÁCIL DE INSTALAR
- FILTRO INTEGRADO

La PIUSI PANTHER AC es una versátil bomba eléctrica giratoria de paletas de transferencia con cebado automático, disponible en tres versiones (56 - 72 - 90) especialmente adecuada para dispensadores, sistemas de transferencia de combustible fijos y otras aplicaciones industriales. Está equipada con una válvula de derivación y un filtro incorporado para controlar las impurezas.

RENDIMIENTO

HASTA

90 L/MIN

CAUDAL

CA
FUNCIONAMIENTO CONTINUO*

ALIMENTACIÓN



PANTHER 56 (sin embridado)



PANTHER 72 - PANTHER 90 (con embridado)



PACKAGING

CÓDIGO	PESO		PACKAGING			N. BOX / EUROPALET	
	KG	LBS	MM	PULGADAS	UDS./CAJA	✈	🚛
PANTHER 56							
FO0730000	7,4	16,3	345X175X255	-	1	60	84
000731000	7,4	16,3	345X175X255	-	1	60	84
000733000	7,4	16,3	345X175X255	-	1	60	84
PANTHER 72							
000732000	7,9	17,4	345X175X255	-	1	60	84
000735000	7,9	17,4	345X175X255	-	1	60	84
PANTHER 90							
FO0733020	8,2	19,9	345X175X255	-	1	60	84



FILTRACIÓN



MONITOREO DE DEPOSITO



ENROLLADORES DE MANGUERA



ACCESORIOS



MATERIAL PROMOCIONAL

INDEX



AIRE



ANTICONG.



AdBlue®



BIODIÉSEL



DIÉSEL



ALIMENTOS



GASOLINA



GRASA



QUEROSENO



ACEITE



AGUA



LIMPIAPARAB.

GRÁFICO

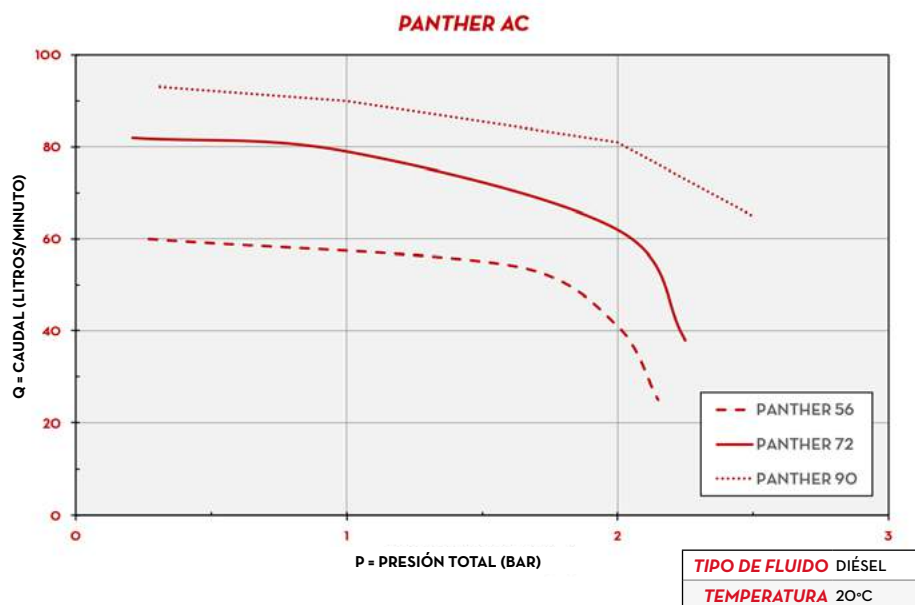

CONTENIDO DE LA CAJA

- BOMBA PANTHER AC
- MANUAL DE INSTRUCCIONES

DETALLES



DIMENSIONES

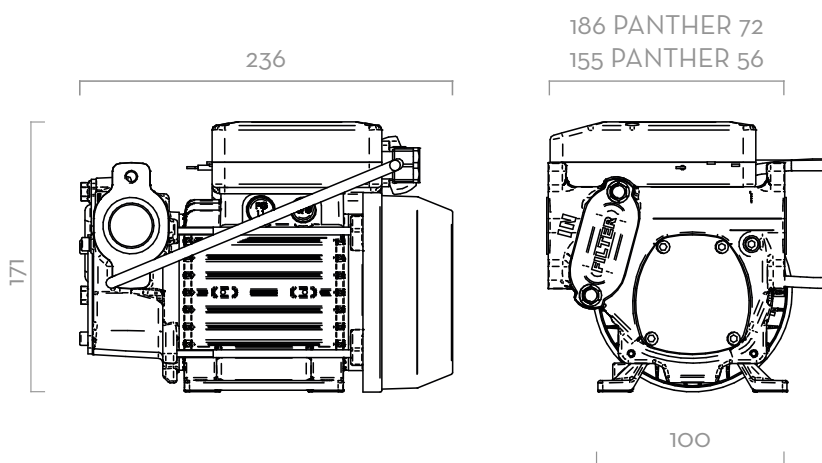

Las dimensiones se expresan en milímetros

MATERIALES

- CUERPO: HIERRO FUNDIDO
- ROTOR: ACERO SINTERIZADO
- PALETAS: TECNOPOLÍMERO
- EJE: ACERO



BOMBA



DEPOSITO

- > MÁX. 6 M (20 FT),
- > MANGUERA DE SUCCIÓN Ø 1" MÍN.,
- > ALTURA MÁX. DE SUCCIÓN:
 - 2M (7FT) SIN VÁLVULA ANTIRRETORNO
 - 4M (14FT) CON VÁLVULA ANTIRRETORNO

FICHA TÉCNICA

CÓDIGO	DESCRIPCIÓN	TIPO DE FLUIDO	CAUDAL		TENSIÓN				RPM	ENTRADA/SALIDA BSP	CONEXIONES EMBRIDADAS	VÁLVULA DERIVA- CIÓN	FILTRO DE ENTRADA
			L/MIN	GPM	MOTOR MONOFÁSICO V/HZ	MOTOR TRIFÁSICO V/HZ	POTEN- CIA/ VATIOS	AMP. MÁX.					
PANTHER 56													
FO0730000	PANTHER 56 230/50	D	56	15	230/50	-	350	3	2900	1"	-	sí	sí
000731000	PANTHER 56 230/60	D	68	18	230/60	-	500	3,9	3400	1"	-	sí	sí
000733000	PANTHER 56 400/50	D	56	15	-	400/50	500	1,3	2900	1"	-	sí	sí
PANTHER 72													
000732000	PANTHER 72 230/50	D	72	19	230/50	-	500	4,2	2900	1"	sí	sí	sí
000735000	PANTHER 72 400/50	D	72	19	-	400/50	500	1,6	2900	1"	sí	sí	sí
PANTHER 90													
FO073302A	PANTHER 90 230/50	D	90	23,8	230/50	-	700	4,9	2900	1"	sí	sí	sí

SE PUEDE PEDIR CON DIFERENTE TENSIÓN Y 60 HZ DE FRECUENCIA. (*) EXCEPTO LA PANTHER 90

PANTHER AC