



SISTEMA DE GESTIÓN DE COMBUSTIBLE



DISPENSADORES



KITS



BOMBAS



MEDIDORES



PISTOLAS

FILTROLL

CARACTERÍSTICAS

- FILTRADO DE DOBLE ETAPA
- TUBO ESPIRAL
- FÁCIL DE MANIPULAR
- RUEDAS DE GRAN DIÁMETRO

PIUSI FILTROLL es una innovadora unidad portátil que ofrece una completa capacidad de filtrado doble para cualquier tipo de tanque, mientras absorbe el agua y las impurezas. El robusto carrito integrado permite al operador manipular con facilidad este dispositivo en cualquier circunstancia. Está equipado con un tubo de succión y una válvula inferior integrada.

RENDIMIENTO

HASTA

56 L/MIN

CAUDAL

CA/CC

TENSIÓN

ALIMENTACIÓN

30µ

ABSORCIÓN DE AGUA

FILTRADO

5µ

IMPUREZAS

FILTRADO



FILTROLL

PACKAGING

CÓDIGO	PESO		PACKAGING		
	KG	LBS	MM	PULGADAS	UDS./CAJA
FO0506000	35	77,2	790X590X590	31,1X23,2X23,2	1
FO050606A	40	88,2	790X590X590	31,1X23,2X23,2	1



FILTRACIÓN



MONITOREO DE DEPOSITO



ENROLLADORES DE MANGUERA



ACCESORIOS



MATERIAL PROMOCIONAL

PIUSI

INDEX



AIRE



ANTICONG.



AdBlue®



BIODIÉSEL



DIÉSEL



ALIMENTOS



GASOLINA



GRASA



QUEROSENO



ACEITE



AGUA



LIMPIAPARAB.

GRÁFICO

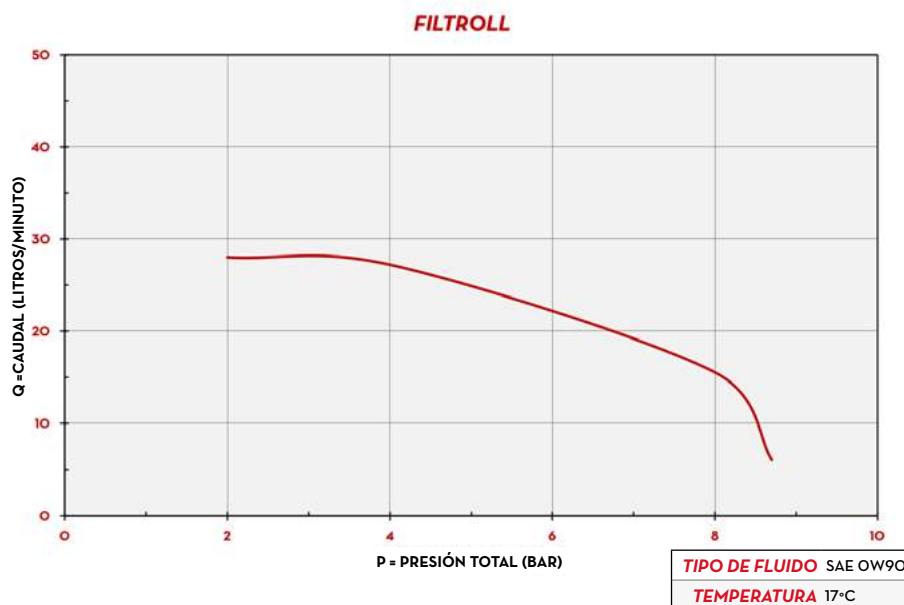

CONTENIDO DE LA CAJA

- UNIDAD FILTROLL
- MANGUERA DE SUCCIÓN
- MANGUERA DE SUMINISTRO
- PISTOLA
- MANUAL DE INSTRUCCIONES

DETALLES



FILTRACIÓN EN DOS ETAPAS



FILTROS DE AGUA/IMPUREZAS

DIMENSIONES

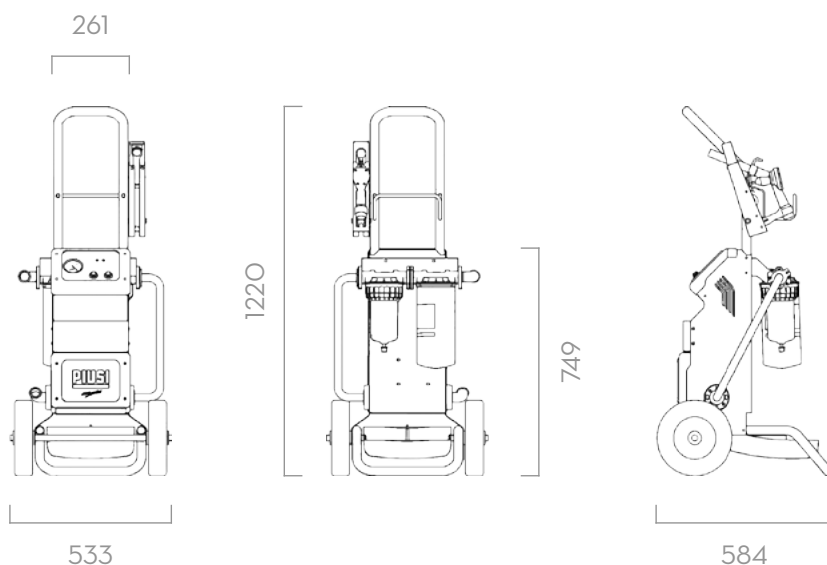

Las dimensiones se expresan en milímetros

MATERIALES

- CUERPO: HIERRO FUNDIDO
- ROTOR: ACERO SINTERIZADO
- PALETAS: TECNOPOLÍMERO
- EJE: ACERO
- FILTRO: PAPEL FILTRANTE ABSORBENTE

FICHA TÉCNICA

CÓDIGO	DESCRIPCIÓN	TIPO DE FLUIDO	CAUDAL		TENSION			BOMBA	LONGITUD DE MANGUERA	
			L/MIN	GPM	V. CA /HZ V. CC	POTENCIA/ VATIOS	AMP. MÁX.	TIPO	SUMINISTRO M/FT.	SUCCIÓN M/FT
FO0506000	FILTROLL DIESEL	D	56	14,8	230/50-60	350/600	3/6	PANTH. 56	4 / 13,1	3 / 9,8
FO050606A	FILTROLL 12V DIESEL	D	56	14,8	12	300	35	PANTH. DC	4 / 13,1	4 / 13,1

DISPONIBLE EN VERSIÓN DE 230 V/60 HZ, 120 V/60 HZ

FILTROLL