



SISTEMA DE GESTIÓN DE COMBUSTIBLE



DISPENSADORES



KITS



BOMBAS



MEDIDORES



PISTOLAS

# E80 / E120

## CARACTERÍSTICAS

- VERSATILIDAD
- ESTRUCTURA ROBUSTA
- LARGA DURACIÓN
- LISTA PARA TRABAJAR
- PROTECCIÓN TÉRMICA

Las bombas PIUSI E80 y E120 son bombas eléctricas giratorias de paletas con cebado automático, compactas y fáciles de instalar, idóneas para satisfacer todas las necesidades de uso que requieran un producto de gran rendimiento y larga duración. Sus robusta estructura junto con la protección térmica y los componentes de gran calidad permiten su uso a bajas temperaturas.

### RENDIMIENTO

HASTA

**100 L/MIN**

CAUDAL

FUNCIONAMIENTO

**CA**

CONTINUO  
ALIMENTACIÓN

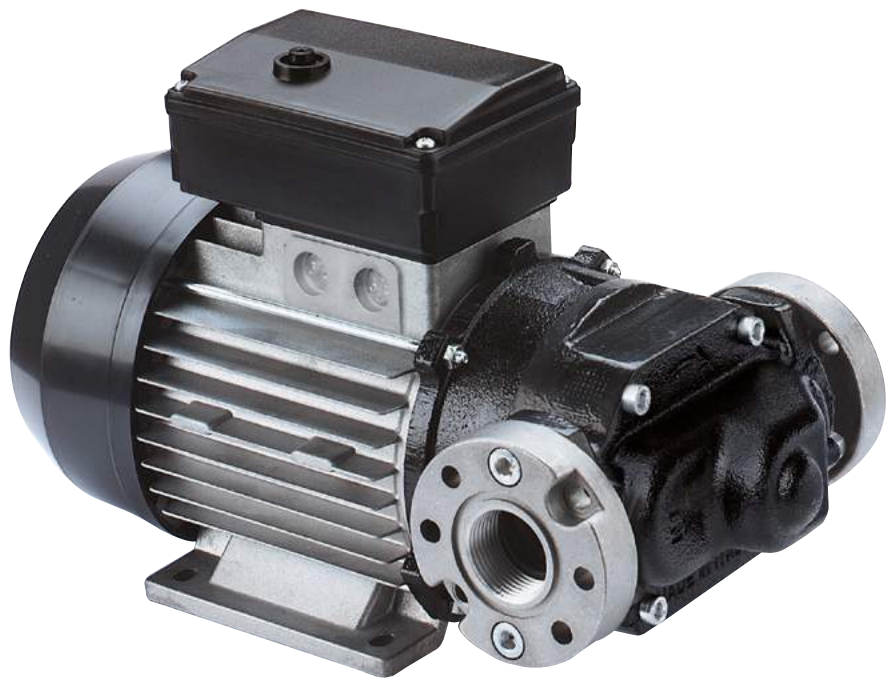

E80/E120



### PACKAGING

CÓDIGO	PESO		PACKAGING			N. BOX / EUROPALET	
	KG	LBS	MM	PULGADAS	UDS./CAJA	✈	🚚
<b>E80</b>							
000305000	13	28,7	355X185X285	-	1	60	72
000307000	13	28,7	355X185X285	-	1	60	72
<b>E120</b>							
000326000	15,6	34,4	355X185X285	-	1	60	72
000312000	15,6	34,4	355X185X285	-	1	60	72



FILTRACIÓN



MONITOREO DE DEPOSITO



ENROLLADORES DE MANGUERA



ACCESORIOS



MATERIAL PROMOCIONAL

INDEX



AIRE



ANTICONG.



AdBlue®



BIODIÉSEL



DIÉSEL



ALIMENTOS



GASOLINA



GRASA



QUEROSENO



ACEITE



AGUA



LIMPIAPARAB.

## GRÁFICO

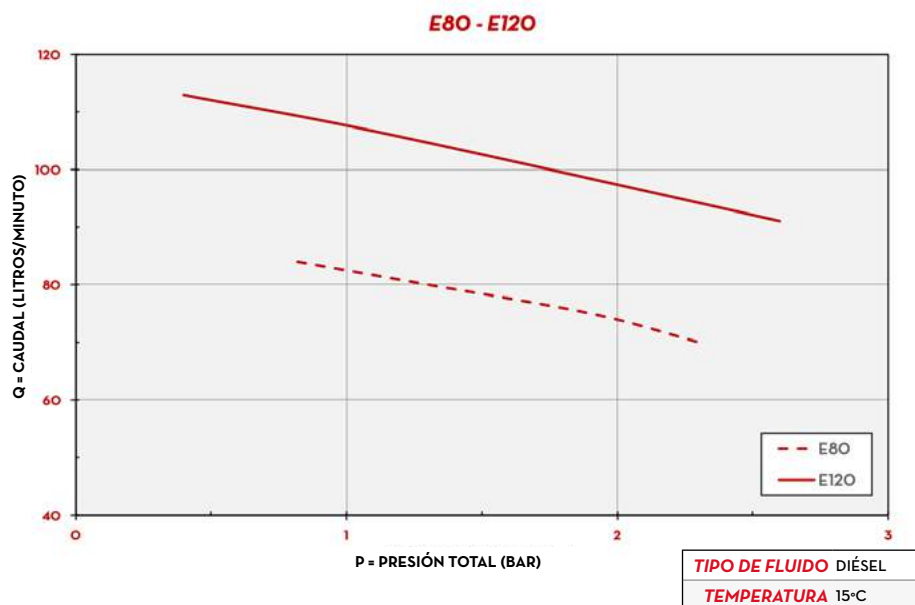

## CONTENIDO DE LA CAJA

- BOMBA E80 / E120
- CONEXIONES EMBRIDADAS
- MANUAL DE INSTRUCCIONES

## DETALLES



## DIMENSIONES

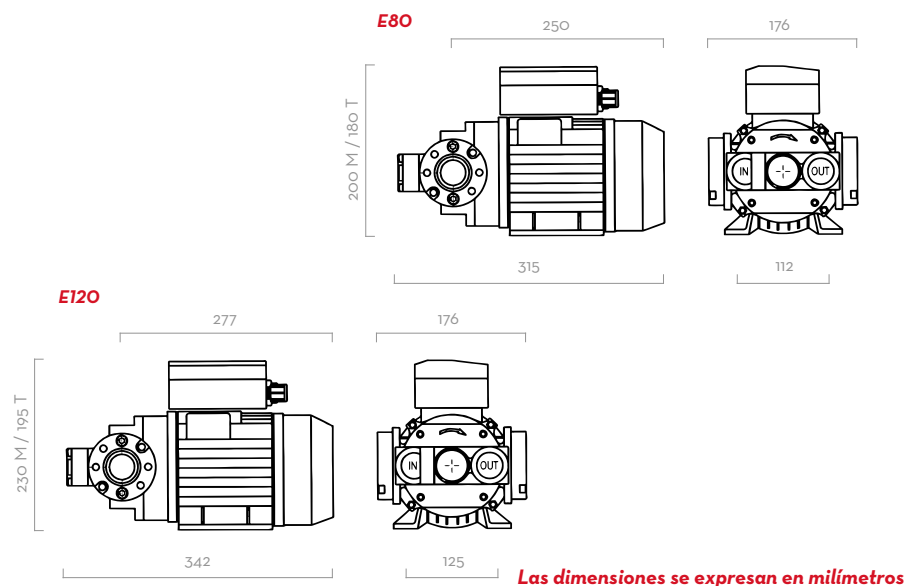

## MATERIALES

- CUERPO: HIERRO FUNDIDO
- ROTOR: ACERO SINTERIZADO
- PALETAS: RESINA ACETÁLICA
- JUNTA: VITON
- EJE: ACERO



BOMBA

- > MÁX. 6 M (20 FT),
- > MANGUERA DE SUCCIÓN Ø 1" MÍN.,
- > ALTURA MÁX. DE SUCCIÓN:
  - 2M (7FT) SIN VÁLVULA ANTIRRETORNO
  - 4M (14FT) CON VÁLVULA ANTIRRETORNO



DEPÓSITO

## FICHA TÉCNICA

CÓDIGO	DESCRIPCIÓN	TIPO DE FLUIDO	CAUDAL		TENSIÓN				RPM	ENTRADA/SALIDA BSP	CONEXIONES EMBRIDADAS	VÁLVULA DERIVACIÓN	FILTRO DE ENTRADA
			L/MIN	GPM	MOTOR MONOFÁSICO V/HZ	MOTOR TRIFÁSICO V/HZ	POTENCIA/ VATIOS	AMP. MÁX.					
<b>E80</b>													
000305000	E 80 M	D	70	18	230/50	-	500	3,5	1400	1"	SÍ	SÍ	NO
000307000	E 80 T	D	70	18	-	400/50	550	1,6	1450	1"	SÍ	SÍ	NO
<b>E120</b>													
000326000	E 120 M	D	100	26	230/50	-	750	5,7	1450	1"	SÍ	SÍ	NO
000312000	E 120 T	D	100	26	-	400/50	750	2,2	1450	1"	SÍ	SÍ	NO

# E80 / E120