



LLENADO DE VEHÍCULOS



SISTEMA DE GESTIÓN DE COMBUSTIBLE



KITS



BOMBAS



MEDIDORES



MEDIDORES PARA PISTOLA

DELPHIN PRO

CARACTERÍSTICAS

- TOTALMENTE AUTOMÁTICO
- SIN NECESIDAD DE OPERADOR
- 100% COMPATIBLE CON TODOS LOS VEHÍCULOS**
- DISEÑO ROBUSTO
- FÁCIL DE CONDUCIR
- REGULADOR DE CAUDAL

DELPHIN PRO es el sistema de llenado de AdBlue® más famoso de PIUSI: permite pasar de repostajes manuales a un sistema automático de llenado de AdBlue®. Compacto, portátil, fiable y robusto, DELPHIN PRO se puede utilizar en todas las condiciones de trabajo. Es completamente automático, solo se necesitan 2 minutos para llenar el depósito de AdBlue®, y su boquilla patentada evita que el AdBlue® se cristalice y no requiere mantenimiento o limpieza.

RENDIMIENTO

2-11 L/MIN

DE CAUDAL

CA

TENSIÓN DE ALIMENTACIÓN

2M

DE LONGITUD DE MANGUERA



DELPHIN PRO



PACKAGING

CÓDIGO	PESO		PACKAGING		
	KG	LBS	MM	PULGADAS	UDS./CAJA
FO010020B	37	81,5	770X1080X800	0,3X42X31,5	1
FO010021B	37	81,5	770X1080X800	0,3X42X31,5	1



PISTOLAS



FILTRACIÓN



MONITOREO DE DEPÓSITO



ENROLLADORES DE MANGUERA



ACCESORIOS



MATERIAL PROMOCIONAL

INDEX



CONEXIÓN DE AIRE



ANTI-CONGELANTE



AdBlue®



BIODIÉSEL



GASÓLEO



ALIMENTOS



GASOLINA



GRASA



QUEROSENO



ACEITE



AGUA



LIMPIA-PARABRISAS

CARACTERÍSTICAS CLAVE



ENCIENDA DELPHIN PRO



USE EL REGULADOR PARA AJUSTAR EL CAUDAL



CONECTE EL CONECTOR AL DEPÓSITO DEL VEHÍCULO



PULSE EL BOTÓN DE LLNADO DURANTE 5 SEG.



UNA VEZ LLENO EL DEPÓSITO, DELPHIN PRO DETIENE AUTOMÁTICAMENTE EL SUMINISTRO

DIMENSIONES

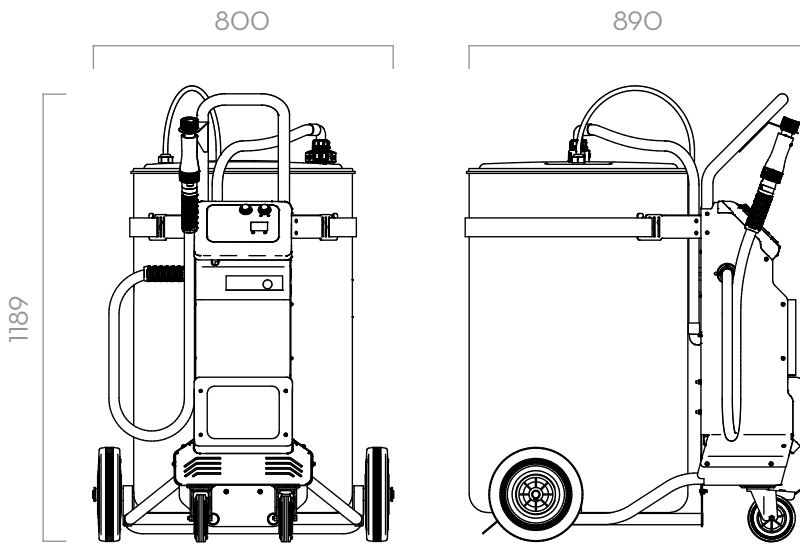

Las dimensiones se expresan en milímetros

CONTENIDO DE LA CAJA

- UNIDAD DELPHIN PRO
- CONECTOR AF2/SEC
- MANUAL DE INSTRUCCIONES

DETALLES



CONECTOR ISO UNIVERSAL



DISPONIBLE EN VERSIÓN SEC



MEDIDOR DIGITAL

MATERIALES

- BOMBA:
- CUERPO: POLIPROPILENO
- MEMBRANA: POLIPROPILENO

FICHA TÉCNICA

CÓDIGO	DESCRIPCIÓN	TIPO DE FLUIDO	CAUDAL		TENSIÓN			MANGUERA		ON/OFF
			L/MIN	GPM	CA V./HZ CC VOLT	POTENCIA WATT	AMP. MAX.	LONGITUD	Ø	SWITCH
FO010020B	DELPHIN PRO 120/230V-50/60HZ		2 - 11	0,5 - 2,9	230/50	400	1,95	2 M	3/4"	SI
FO010021B	DELPHIN PRO 120/230V-50/60HZ W/SEC CONN		2 - 11	0,5 - 2,9	230/50	400	1,95	2 M	3/4"	SI

** DE CONFORMIDAD CON LA NORMA ISO/FDIS 22241--4:2009

DELPHIN PRO

SISTEMAS DE LLENADO