



SISTEMA DE GESTIÓN DE COMBUSTIBLE



DISPENSADORES



KITS



BOMBAS



MEDIDORES



PISTOLAS

# CUBE

## CARACTERÍSTICAS

- ESTRUCTURA ROBUSTA
- MEDIDOR MECÁNICO
- MOTOR DE INDUCCIÓN CON PROTECCIÓN TÉRMICA
- PROTECCIÓN CONTRA SOBRECARGAS
- FILTRO DE MALLA INTEGRADO
- IP 55

PIUSI CUBE es una gama de dispensadores mecánicos de transferencia de combustible para uso no comercial. Se compone de una bomba de paletas de cebado automático equipada con una válvula de derivación integrada, una pistola automática con conexión giratoria y un soporte de pistola integrado con palanca de arranque y parada de la bomba. Su versatilidad permite diferentes aplicaciones: en paredes, tanques, cisternas, bidones o funcionamiento autónomo (con el pedestal opcional).

### RENDIMIENTO

HASTA  
**90 L/MIN**

CAUDAL

**CA/CC**  
ALIMENTACIÓN

TENSIÓN

**±1%**

PRECISIÓN



CUBE 56 CON FILTRO



CUBE 56 CON PEDESTAL (OPTIONAL)

### PACKAGING

CÓDIGO	PESO		PACKAGING			N. BOX / EUROPALLET	
	KG	LBS	MM	PULGADAS	UDS./CAJA	✈	🚚
FO0575400	22	46	400X400X460	-	1	12	24
OO057516A	21	46	400X400X460	-	1	12	24
OO057500C	21	46	400X400X460	-	1	12	24
FO057600C	21	46	400X400X460	-	1	12	24
FO057700C	21	46	400X400X460	-	1	12	24
FO0591200	22	48	400X400X460	-	1	12	24
FO059100A	21	46	400X400X460	-	1	12	24
FO059111A	21	46	400X400X460	-	1	12	24
FO0592000	22	46	400X400X460	-	1	12	24



FILTRACIÓN



MONITOREO DE DEPOSITO



ENROLLADORES DE MANGUERA



ACCESORIOS



MATERIAL PROMOCIONAL

INDEX



AIRE



ANTICONG.



AdBlue®



BIODIÉSEL



DIÉSEL



ALIMENTOS



GASOLINA



GRASA



QUEROSENO



ACEITE



AGUA



LIMPIAPARAB.

## GRÁFICO

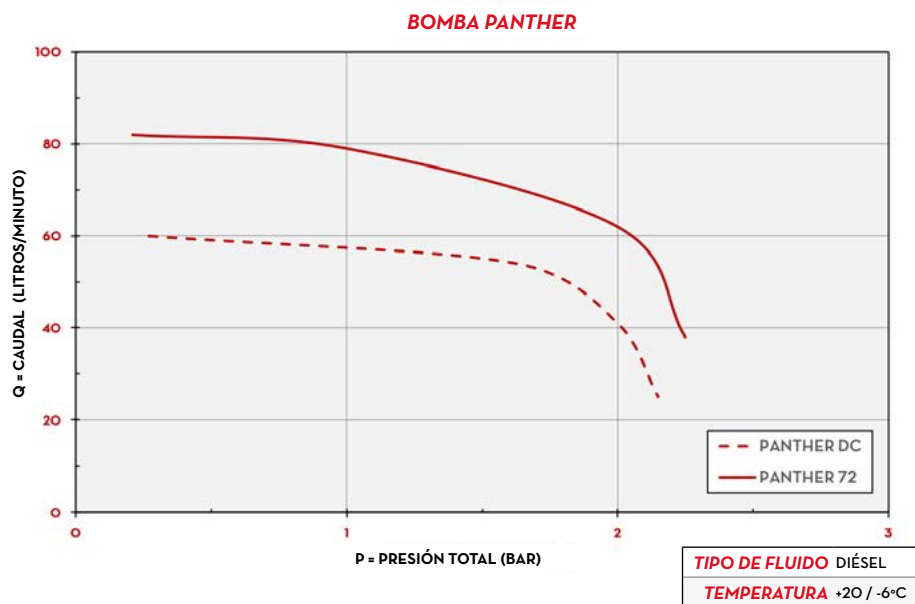

## CONTENIDO DE LA CAJA

- DISPENSADOR CUBE
- PISTOLA AUTOMÁTICA
- MANGUERA DE SUMINISTRO
- MANUAL DE INSTRUCCIONES

## DETALLES



## DIMENSIONES

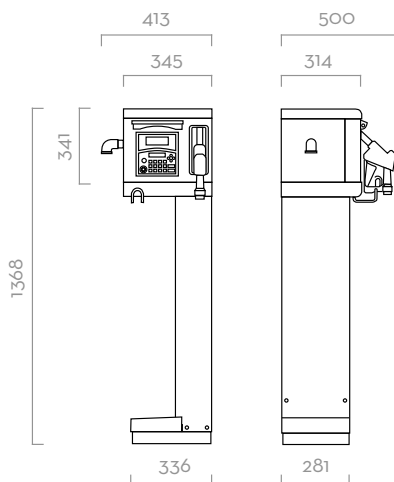

Las dimensiones se expresan en milímetros

## COMPONENTES

- **BOMBA:**  
PANTHER AC PÁG. 102  
PANTHER DC PÁG. 114
- **MEDIDOR:**  
K33 / K44 PÁG. 146
- **PISTOLA:**  
PISTOLA AUTOMÁTICA PÁG. 158

## FICHA TÉCNICA

CÓDIGO	DESCRIPCIÓN	TIPO DE FLUIDO	CAUDAL		TENSIÓN			BOMBA	MEDIDOR	PISTOLA	FILTRO		ENTRADA	MANGUERA	
			L/MIN	GPM	V. CA / HZ V. CC	POTENCIA / VATIOS	AMP. MÁX.				H2O FILTER	CAPACIDAD DE FILTRADO		BSP	METERS
FO0575400	CUBE 56/33 + FILTER	D	56	15	230/50	350	3	PANTH 56	K33	A60	SÍ	30 µ	1"	6M	3/4"
OO057516A	CUBE 56/44 PULSER	D	56	15	230/50	350	3	PANTH 56	K44	A60	NO	-	1"	4M	3/4"
OO057500C	CUBE 56/33	D	56	15	230/50	350	3	PANTH 56	K33	A60	NO	-	1"	4M	3/4"
FO057600C	CUBE 56 DC 12V	D	56	15	12	300	35	PANTH DC	K33	A60	NO	-	1"	4M	1"
FO057700C	CUBE 70 DC 24V	D	70	18	24	420	25	PANTH DC	K33	A60	NO	-	1"	4M	3/4"
FO0591200	CUBE 70/33 + FILTER	D	70	18	230/50	500	4,2	PANTH 72	K33	A60	SÍ	30 µ	1"	6M	1"
FO059100A	CUBE 70/33	D	70	18	230/50	500	4,2	PANTH 72	K33	A60	NO	-	1"	4M	1"
FO059111A	CUBE 70/44 PULSER	D	70	18	230/50	500	4,2	PANTH 72	K44	A60	NO	-	1"	4M	1"
FO0592000	CUBE 90/44	D	90	23,8	230/50	700	4,9	PANTH 90	K44	A120	NO	-	1"	4M	1"

SE PUEDE PEDIR CON DIFERENTE TENSIÓN Y 50/60 HZ DE FRECUENCIA

# CUBE