



SISTEMA DE GESTIÓN DE COMBUSTIBLE



DISPENSADORES



KITS



BOMBAS



MEDIDORES



PISTOLAS

E300

CARACTERÍSTICAS

- BOMBA DE GRAN CAUDAL
- ESTRUCTURA ROBUSTA
- APLICACIÓN EN USO INTENSIVO
- IP44

La PIUSI E300 es una bomba eléctrica con impulsor abierto, idónea para todas aquellas aplicaciones en las que se precise un gran caudal. Por tanto, es el equipo ideal para rellenar y transferir combustible diésel desde bidones. Incorpora una válvula de retención en la toma de succión para evitar el efecto sifón al tiempo que garantiza el recebado automático.

RENDIMIENTO

HASTA

550 L/MIN

CAUDAL

FUNCIONAMIENTO

CA

CONTINUO
ALIMENTACIÓN

1,8 BAR

FUNCIONAMIENTO
MÁX

PRESIÓN

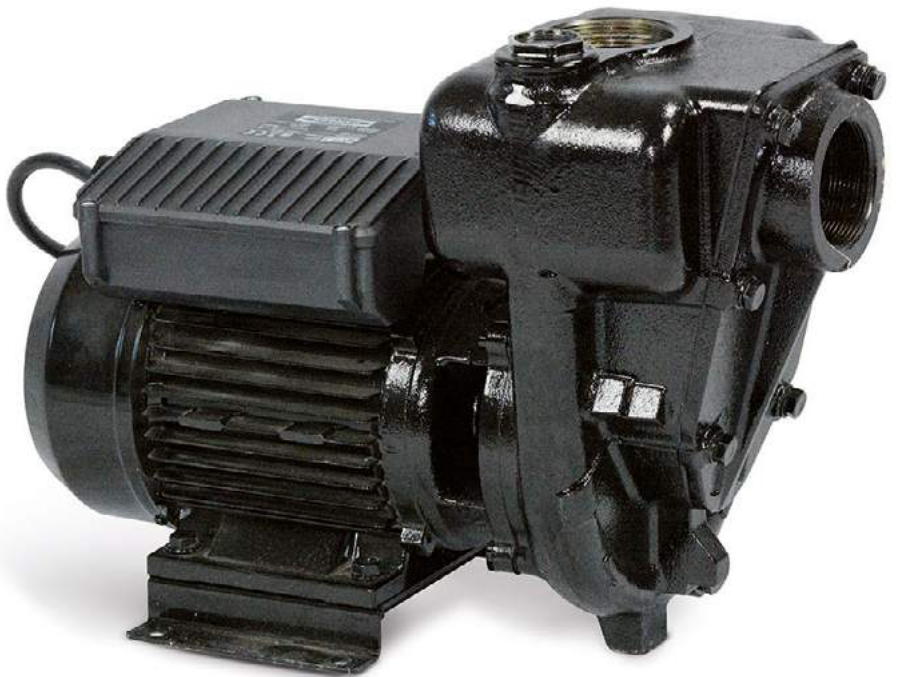

E300



PACKAGING

CÓDIGO	PESO		PACKAGING		
	KG	LBS	MM	PULGADAS	UDS./CAJA
FO0321000	28	61,7	220X420X330	8,7X16,5X13	1



FILTRACIÓN



MONITOREO DE DEPOSITO



ENROLLADORES DE MANGUERA



ACCESORIOS



MATERIAL PROMOCIONAL

INDEX



AIRE



ANTICONG.



AdBlue®



BIODIÉSEL



DIÉSEL



ALIMENTOS



GASOLINA



GRASA



QUEROSENO



ACEITE



AGUA



LIMPIAPARAB.

GRÁFICO



TIPO DE FLUIDO DIÉSEL

TEMPERATURA 10°C

DIMENSIONES

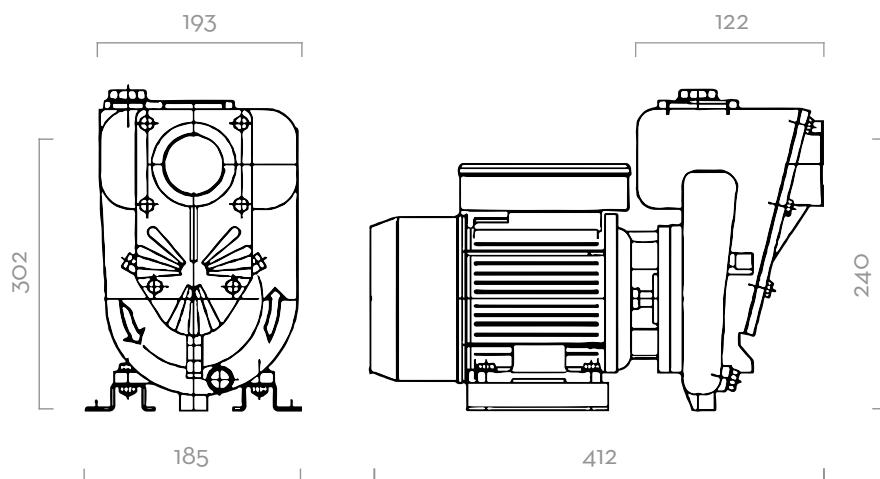

Las dimensiones se expresan en milímetros

CONTENIDO DE LA CAJA

- BOMBA E300
- MANUAL DE INSTRUCCIONES

DETALLES



IMPULSOR ABIERTO



CONEXIONES DE ENTRADA Y SALIDA DE 2"



SOPORTE ESTABLE

COMPONENTES

- CUERPO: HIERRO FUNDIDO
- ROTOR: ACERO SINTERIZADO
- PALETAS: RESINA ACETÁLICA
- JUNTA: VITON
- EJE: ACERO

FICHA TÉCNICA

CÓDIGO	DESCRIPCIÓN	TIPO DE FLUIDO	CAUDAL		TENSIÓN			RPM	ENTRADA/SALIDA
			L/MIN	GPM	CA VOLT/HZ	POTENCIA/VATIOS	AMP. MÁX.		BSP
FO0321000	E 300	D	550	132	230/50	1500	9,2	2580	2"

E300