



KITS



BOMBAS



MEDIDORES

MEDIDORES
PARA PISTOLA

PISTOLAS

EQUIPO DE
RECUPERACIÓN DE ACEITE

DEPUROIL

CARACTERÍSTICAS

- IDEAL PARA DIÁLISIS DE ACEITE
- TAMAÑO COMPACTO
- SILENCIOSO
- INDICADOR DE OBSTRUCCIÓN
- 5 METROS DE CABLE
- TUBOS ESPIRALES

DEPUROIL de PIUSI es una unidad de filtrado inmediato portátil: la solución más sencilla de filtración de un solo paso, adecuada para cualquier tipo de depósito. Incluye la bomba VISCOMAT VANE de PIUSI, adecuada para lubricantes de viscosidad baja y media.

RENDIMIENTO

HASTA

50L

CAPACIDAD DE DEPÓSITO

CA

TENSIÓN

POTENCIA



DEPUROIL

PACKAGING

CÓDIGO	PESO		PACKAGING			
	KG	LBS	MM	PULGADAS	UDS. /PALÉ	UDS. /CAJA
00050300A	28	61,7	600X290X300	23,6X11,4X11,8		1
FO0503100	28	61,7	600X290X300	23,6X11,4X11,8		1



FILTRACIÓN



SUPERVISIÓN DE FLUIDOS



MONITOREO DE DEPOSITO



ENROLLADORES DE MANGUERA



ACCESORIOS



MATERIAL PROMOCIONAL

INDEX



AIRE



ANTICONGELANTE



AdBlue®



BIODIÉSEL



DIÉSEL



ALIMENTOS



GASOLINA



GRASA



QUEROSENO



ACEITE



AGUA



LIMPIAPARABRISAS

GRÁFICO

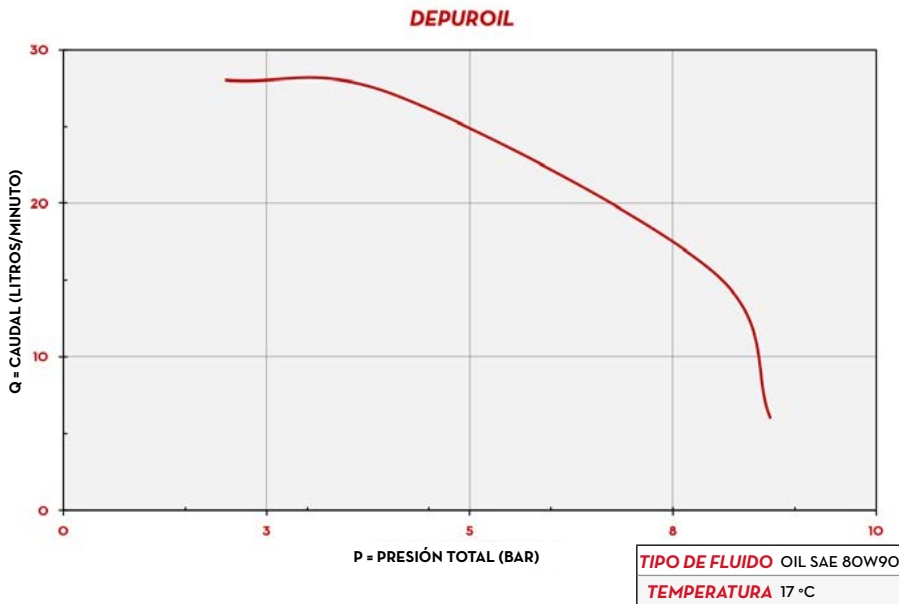

CONTENIDO DE LA CAJA

- DEPUROIL
- CARTUCHO DE FILTRO
- MANGUERA DE SUCCIÓN
- MANGUERA DE SUMINISTRO
- MANUAL DE INSTRUCCIONES

DETALLES



RUEDAS DE GRAN DIÁMETRO



ESTRUCTURA ROBUSTA

DIMENSIONES

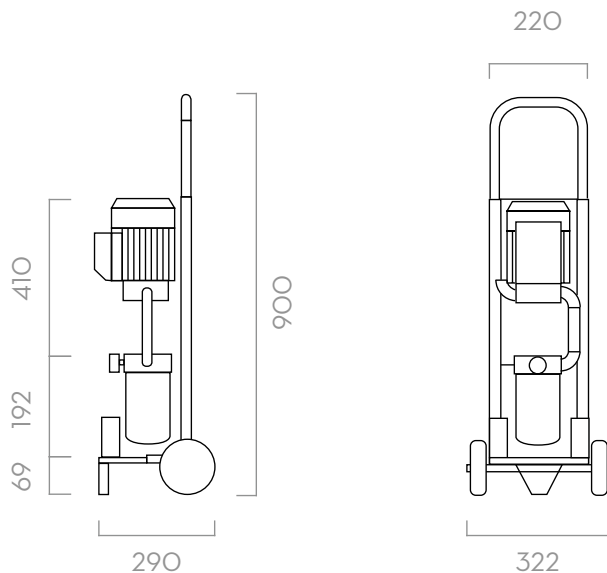

Las medidas se expresan en milímetros

MATERIALES

- CUERPO: HIERRO FUNDIDO
- ROTOR: ACERO SINTERIZADO
- PALETAS: TECNOPOLÍMERO
- EJE: ACERO
- FILTRO: PAPEL FILTRANTE ABSORBENTE

FICHA TÉCNICA

CÓDIGO	DESCRIPCIÓN	TIPO DE FLUIDO	CAUDAL		TENSIÓN			BOMBA	LONG. MANGUERA		CAPACIDAD DE FILTRADO MU
			L/MIN	GPM	V. CA/HZ V. CC	POTENCIA VATIOS	AMP. MÁX.		SUMINISTRO M/ET	SUCCIÓN M/ET	
00050300A	DEPUROIL M 230V/50HZ		20-25	5,28-6,6	230/50	1350	6,2	VISCOMAT 70	2 / 6,5	2 / 6,5	10
FO0503100	DEPUROIL 60		50	13	230/50	1350	6,2	VISCOMAT 90	2	2	10

DEPUROIL

SISTEMA DE FILTRACIÓN

127