



KITS



BOMBAS



MEDIDORES

MEDIDORES
PARA PISTOLA

PISTOLAS

EQUIPO DE
RECUPERACIÓN DE ACEITE

FILTROLL

CARACTERÍSTICAS

- FILTRADO DE DOBLE ETAPA
- INDICADOR DE OBSTRUCCIÓN
- TRANSPORTABLE
- MANEJABLE
- TUBOS ESPIRALES

FILTROLL de PIUSI es una solución innovadora que permite al usuario realizar un filtrado circular de cualquier tipo de depósito. El carrito integrado permite al operador manipular fácilmente este dispositivo en cualquier circunstancia.

RENDIMIENTO

HASTA

25L/MIN

CAUDAL

CA

TENSIÓN

POTENCIA

VERSIÓN DE DC

30MIN

SOLO PARA DIÉSEL

CICLO DE SERVICIO

**FILTROLL OIL/DIESEL**

PACKAGING

CÓDIGO	PESO		PACKAGING			
	KG	LBS	MM	PULGADAS	UDS. /PALÉ	UDS. /CAJAT
FO0506010	42	92,6	790X590X590	31,1X23,2X23,2		1



FILTRACIÓN



SUPERVISIÓN DE FLUIDOS



MONITOREO DE DEPOSITO



ENROLLADORES DE MANGUERA



ACCESORIOS



MATERIAL PROMOCIONAL

INDEX



AIRE



ANTICONGELANTE



AdBlue®



BIODIÉSEL



DIÉSEL



ALIMENTOS



GASOLINA



GRASA



QUEROSENO



ACEITE



AGUA



LIMPIAPARABRISAS

GRÁFICO

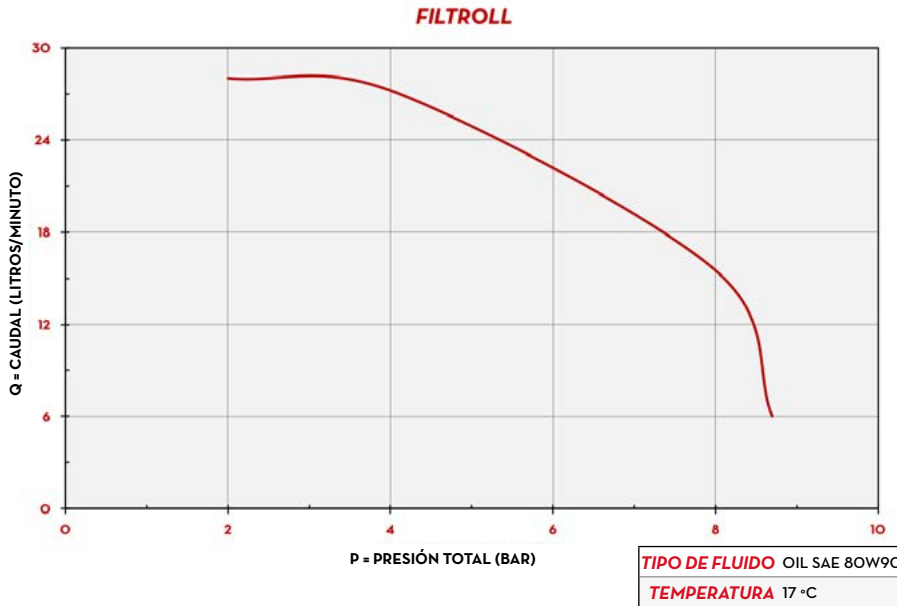

CONTENIDO DE LA CAJA

- UNIDAD FILTROLL
- MANGUERA DE SUCCIÓN
- MANGUERA DE SUMINISTRO
- MANUAL DE INSTRUCCIONES

DETALLES



FILTRACIÓN EN DOS PASOS



ESTRUCTURA ROBUSTA



RUEDAS DE GRAN DIÁMETRO

DIMENSIONES

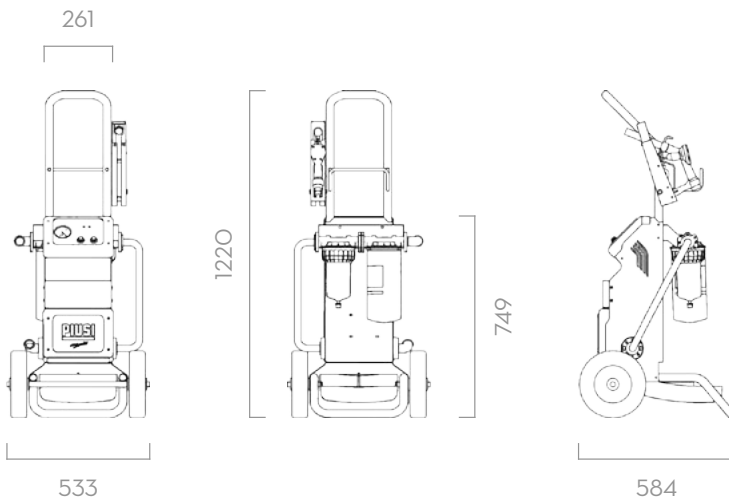

Las medidas se expresan en milímetros

MATERIALES

- CUERPO: HIERRO FUNDIDO
- ROTOR: ACERO SINTERIZADO
- PALETAS: TECNOPOLÍMERO
- EJE: ACERO
- FILTRO: PAPEL FILTRANTE ABSORBENTE

FICHA TÉCNICA

CÓDIGO	DESCRIPCIÓN	TIPO DE FLUIDO	CAUDAL		TENSIÓN			BOMBA	LONG.MANGUERA	
			L/MIN	GPM	V. CA/HZ V. CC	POTENCIA VATIOS	AMP. MÁX.		TIPO	SUMINISTRO M/ET
FO0506010	FILTROLL OIL/DIESEL	D O	25	7	230/50	750	4,6	VISCOMAT 70	3 / 9,8	3 / 9,8

CARTUCHO PARA FILTROS

CÓDIGO	DESCRIPCIÓN	MICRAS	EFICIENCIA
		μ m	
FO061102A	WATER CAPTOR CART. 150 L/MIN	30	200
FO061103O	CLEAR CAPTOR CARTRIDGE	5	2

CABEZA DEL FILTRO

F1693400A	FILTER HEAD 70/10OLT W/MANOM	-	-
F1574400O	CLEAR CAPTOR FILTER HEAD	-	-

FILTROLL

SISTEMA DE FILTRACIÓN

129