



SISTEMA DE GESTIÓN DE COMBUSTIBLE



DISPENSADORES



KITS



BOMBAS



MEDIDORES



PISTOLAS

PANTHER DC

CARACTERÍSTICAS

- ESTRUCTURA ROBUSTA
- FÁCIL DE INSTALAR
- DISEÑO COMPACTO
- IP55

La PANTHER DC es una bomba giratoria de paletas con cebado automático, idónea para todas aquellas aplicaciones en las que se precisa un caudal importante. Incluye un filtro de 100 μ y una válvula de derivación. La versión de 24/12 V puede utilizarse con ambas tensiones.

RENDIMIENTO

HASTA

70 L/MIN

CAUDAL

12/24V

TENSIÓN

ALIMENTACIÓN

30 MIN

CICLO DE SERVICIO



PANTHER DC



PACKAGING

CÓDIGO	PESO		PACKAGING		
	KG	LBS	MM	PULGADAS	UDS./CAJA
FO034000B	7,5	16,5	345X175X255	13,6X6,9X10	1
FO034001B	7,5	16,5	345X175X255	13,6X6,9X10	1
FO034100C	7,5	16,5	345X175X255	13,6X6,9X10	1
FO034101C	7,5	16,5	345X175X255	13,6X6,9X10	1
FO034116C	7,5	16,5	345X175X255	13,6X6,9X10	1



FILTRACIÓN



MONITOREO DE DEPOSITO



ENROLLADORES DE MANGUERA



ACCESORIOS



MATERIAL PROMOCIONAL

INDEX



AIRE



ANTICONG.



AdBlue®



BIODIÉSEL



DIÉSEL



ALIMENTOS



GASOLINA



GRASA



QUEROSENO



ACEITE



AGUA



LIMPIAPARAB.

GRÁFICO

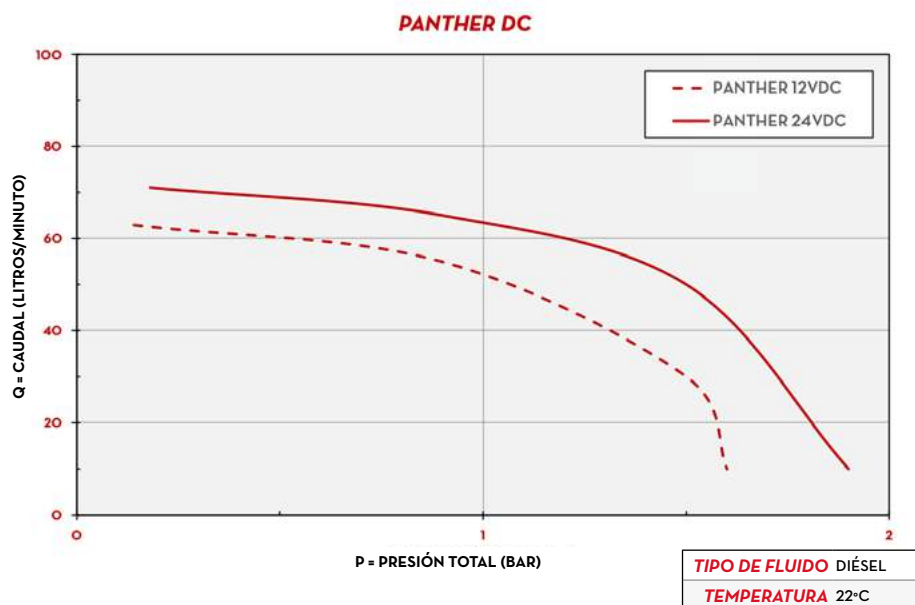

DIMENSIONES

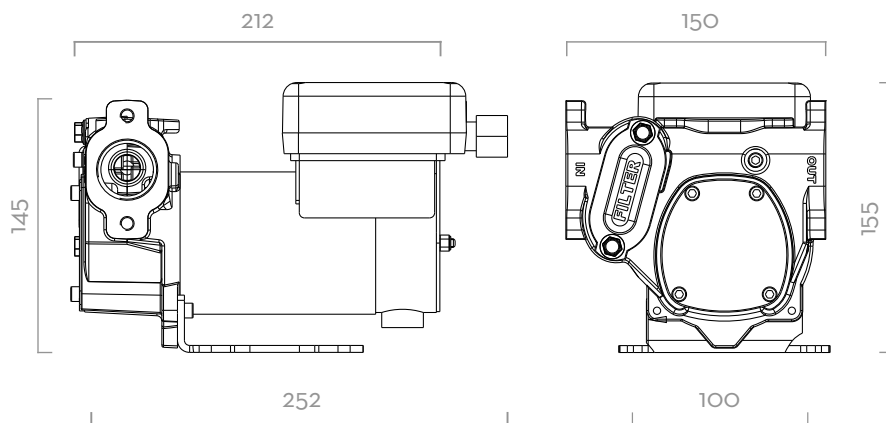

Las dimensiones se expresan en milímetros

CONTENIDO DE LA CAJA

- BOMBA PANTHER DC
- MANUAL DE INSTRUCCIONES

DETALLES



MATERIALES

- CUERPO: HIERRO FUNDIDO
- ROTOR: ACERO SINTERIZADO
- PALETAS: RESINA ACETÁLICA
- MOTOR: CARCASA DE ALUMINIO



BOMBA

- > MÁX. 6 M (20 FT),
- > MANGUERA DE SUCCIÓN Ø 1" MÍN.,
- > ALTURA MÁX. DE SUCCIÓN:
 - 2M (7FT) SIN VÁLVULA ANTIRRETORNO
 - 4M (14FT) CON VÁLVULA ANTIRRETORNO



DEPOSITO

FICHA TÉCNICA

CÓDIGO	DESCRIPCIÓN	TIPO DE FLUIDO	CAUDAL		TENSIÓN			CICLO DE SERVICIO	RPM	SALIDA
			L/MIN	GPM	VOLT CC	POTENCIA/VATIOS	AMP. MÁX.			
FO034000B	PANTHER DC 12V	D	56	14,8	12	300	35	30	2900	1"
FO034001B	PANTHER DC 12V W/CABLE 2MT W/PLIERS	D	56	14,8	12	300	35	30	2900	1"
FO034100C	PANTHER DC 24/12V	D	70 / 35	18,5 / 9,2	24/12	420 / 150	25 / 16	30	3600 / 1800	1"
FO034101C	PANTHER DC 12/24V W/CABLE 2MT W/CLIPS	D	70 / 35	18,5 / 9,2	24/12	420 / 150	25 / 16	30	3600 / 1800	1"
FO034116C	PANTHER DC 12/24V W/CABLE 4MT W/CLIPS	D	70 / 35	18,5 / 9,2	24/12	420 / 150	25 / 16	30	3600 / 1800	1"

PANTHER DC