



# DEPÓSITO PARA EL TRANSPORTE DE DIÉSEL “Diesel Tank 220”



Código	Descrip.	Caudal	Tensión	Potencia	Entra-da-Salida	Man. con.	Pistola	Con-tador	Ciclo de trabajo	Peso	Embalaje
		l/min	AC V./Hz DC Volt	W	BSPG	Ø			min	Kg	mm

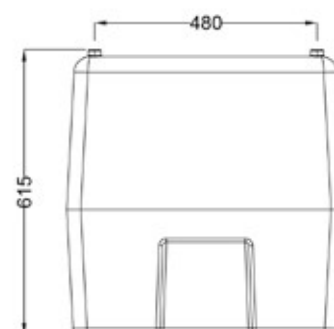
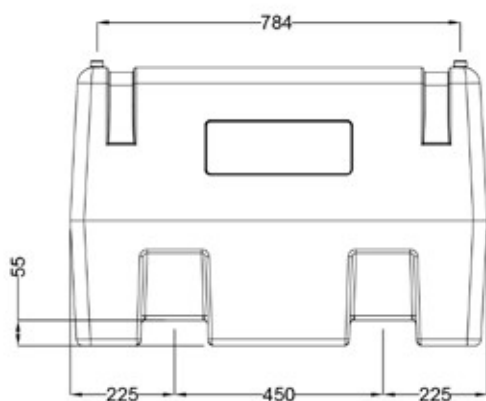

<b>090-6220-012</b>	Tank 220 l	<b>45</b>	12	264	F1" - F1"	20	Aut.PA60	NO	40	25,00	600X910X665
<b>090-6220-024</b>	Tank 220 l	<b>45</b>	24	312	F1" - F1"	20	Aut.PA60	NO	40	25,00	600X910X665

<b>090-6221-012</b>	Tank 220 l	<b>45</b>	12	264	F1" - F1"	20	Aut.PA60	SI	40	25,30	600X910X665
<b>090-6221-024</b>	Tank 220 l	<b>45</b>	24	312	F1" - F1"	20	Aut.PA60	SI	40	25,30	600X910X665



# DEPÓSITO PARA EL TRANSPORTE DE DIÉSEL “Diesel Tank 330”



Código	Descrip.	Caudal	Tensión	Poten- cia	Entra- da- Salida	Man. con.	Pistola	Con- tador	Ciclo de trabajo	Peso	Embalaje
		l/min	AC V./Hz DC Volt	W	BSPG	∅			min	Kg	mm

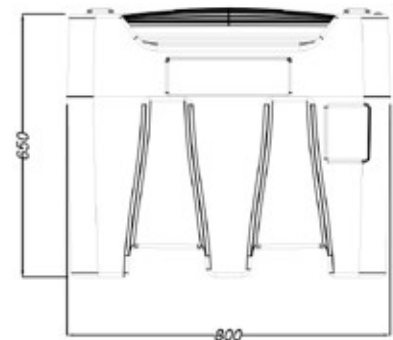
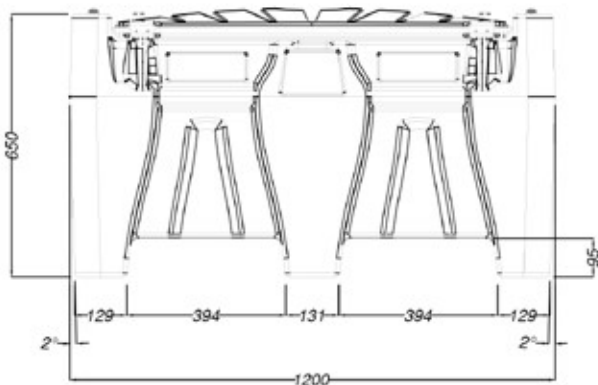

<b>090-6330-012</b>	Tank 330 I	<b>45</b>	12	264	F1" - F1"	20	Aut.PA60	NO	40	44,00	1200x800x650
<b>090-6330-024</b>	Tank 330 I	<b>45</b>	24	312	F1" - F1"	20	Aut.PA60	NO	40	44,00	1200x800x650

<b>090-6331-012</b>	Tank 330 I	<b>45</b>	12	264	F1" - F1"	20	Aut.PA60	SI	40	44,30	1200x800x650
<b>090-6331-024</b>	Tank 330 I	<b>45</b>	24	312	F1" - F1"	20	Aut.PA60	SI	40	44,30	1200x800x650



# DEPÓSITO PARA EL TRANSPORTE DE DIÉSEL “Diesel Tank 440”



Código	Descrip.	Caudal	Tensión	Poten- cia	Entra- da- Salida	Man. con.	Pistola	Con- tador	Ciclo de trabajo	Peso	Embalaje
		l/min	AC V./Hz DC Volt	W	BSPG	Ø			min	Kg	mm

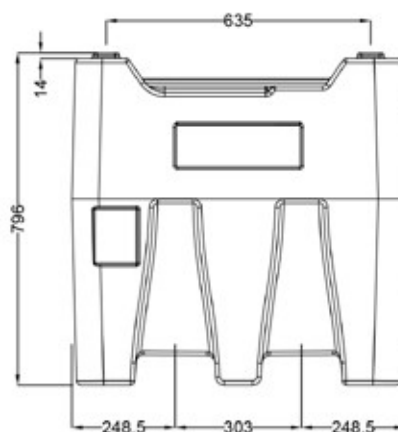
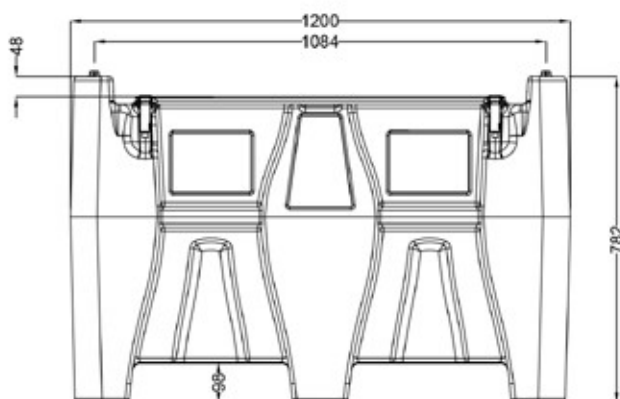

<b>090-6440-012</b>	Tank 440 l	<b>45</b>	12	264	F1" - F1"	20	Aut.PA60	NO	40	53,00	1200x800x785
<b>090-6440-024</b>	Tank 440 l	<b>45</b>	24	312	F1" - F1"	20	Aut.PA60	NO	40	53,00	1200x800x785

<b>090-6441-012</b>	Tank 440 l	<b>45</b>	12	264	F1" - F1"	20	Aut.PA60	SI	40	53,30	1200x800x785
<b>090-6441-024</b>	Tank 440 l	<b>45</b>	24	312	F1" - F1"	20	Aut.PA60	SI	40	53,30	1200x800x785



# DEPÓSITO PARA TRANSPORTE DIÉSEL Y AdBlue® “Diesel-AdBlue® Tank”



Código	Descrip.	Líquido	Caudal	Tensión	Poten- cia	Entra- da- Salida	Man. con..	Pistola	Con- tador	Ciclo de tra- bajo	Peso	Embalaje
			l/min	AC V./Hz DC Volt	W	BSPG	∅			min		

<b>090-6450-012</b>	400 l	Diésel	<b>45</b>	12	264	F1"-F1"	20	Aut.PA60	NO	40	57,00	1200X800X796
	Tank 400 + 50											
	50 l	AdBlue®	<b>15</b>	12	26		19	Man.AD90	NO	-		

<b>090-6451-012</b>	400 l	Diésel	<b>45</b>	12	264	F1"-F1"	20	Aut.PA60	SI	40	57,30	1200X800X796
	Tank 400 + 50											
	50 l	AdBlue®	<b>15</b>	12	26		19	Man.AD90	NO	-		

